

(12) INTERNATIONAL APPLICATION PUBLISHED UNDER THE PATENT COOPERATION TREATY (PCT)

(19) World Intellectual Property Organization
International Bureau



(43) International Publication Date
3 May 2001 (03.05.2001)

PCT

(10) International Publication Number
WO 01/30995 A1

(51) International Patent Classification?: C12N 15/10,
C12M 3/04, B01L 3/00

THOMAS, Philip, Landeg [GB/GB]; 18 Clive Road, Canton. Cardiff CF5 1HJ (GB). KENRICK, Michael, Kenneth [GB/GB]; 4 Emanuel Close, Castleview, Caerphilly (GB).

(21) International Application Number: PCT/GB00/04047

(22) International Filing Date: 20 October 2000 (20.10.2000)

(74) Agents: ROLLINS, Anthony, John et al.; Amersham Pharmacia Biotech UK Limited, Amersham Laboratories, White Lion Road, Amersham, Buckinghamshire HP7 9LL (GB).

(25) Filing Language: English

(26) Publication Language: English

(30) Priority Data:
9925468.2 28 October 1999 (28.10.1999) GB

(81) Designated States (national): AE, AG, AL, AM, AT, AU, AZ, BA, BB, BG, BR, BY, BZ, CA, CH, CN, CR, CU, CZ, DE, DK, DM, DZ, EE, ES, FI, GB, GD, GE, GH, GM, HR, HU, ID, IL, IN, IS, JP, KE, KG, KP, KR, KZ, LC, LK, LR, LS, LT, LU, LV, MA, MD, MG, MK, MN, MW, MX, MZ, NO, NZ, PL, PT, RO, RU, SD, SE, SG, SI, SK, SL, TJ, TM, TR, TT, TZ, UA, UG, US, UZ, VN, YU, ZA, ZW.

(71) Applicant (for all designated States except US): AMERSHAM PHARMACIA BIOTECH UK LIMITED [GB/GB]; Amersham Laboratories, White Lion Road, Amersham, Buckinghamshire HP7 9LL (GB).

(84) Designated States (regional): ARIPO patent (GH, GM, KE, LS, MW, MZ, SD, SL, SZ, TZ, UG, ZW), Eurasian patent (AM, AZ, BY, KG, KZ, MD, RU, TJ, TM), European patent (AT, BE, CH, CY, DE, DK, ES, FI, FR, GB, GR, IE, IT, LU, MC, NL, PT, SE), OAPI patent (BF, BJ, CF, CG, CI, CM, GA, GN, GW, ML, MR, NE, SN, TD, TG).

(72) Inventors; and

(75) Inventors/Applicants (for US only): TOOKE, Nigel, Eric [GB/SE]; Olof Thunmans vag 14, SE-741 44 Knivsta (SE).

[Continued on next page]

(54) Title: DNA ISOLATION METHOD

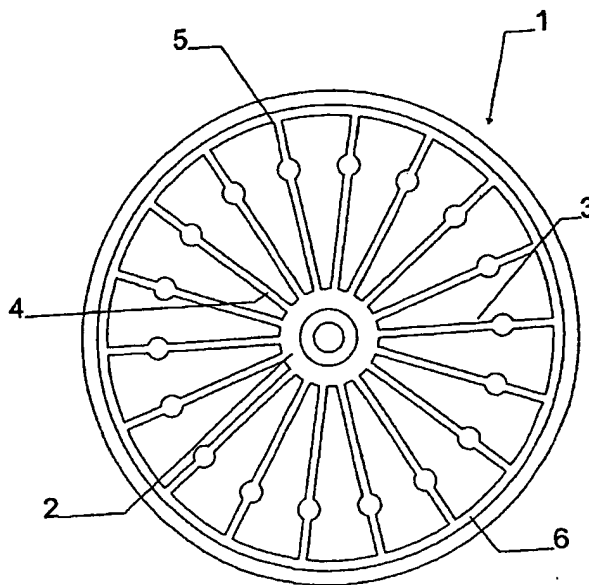

WO 01/30995 A1

(57) Abstract: Disclosed is a method and apparatus for the isolation of DNA or cell nuclei or a mixture thereof from cell samples in a CD device. The method includes treating a suspension of whole cells with a lysis reagent so as to lyse the cytoplasmic membrane and at least some of the nuclear membranes, and introducing the lysate into micro-channels of a microfabricated apparatus in which each of the micro-channels is provided with a barrier disposed in the channel to impede the passage or flow of DNA and cell nuclei while allowing the passage of liquid through the micro-channel so that a mesh comprising DNA is formed in the channel.



Published:

- With international search report.
- Before the expiration of the time limit for amending the claims and to be republished in the event of receipt of amendments.

For two-letter codes and other abbreviations, refer to the "Guidance Notes on Codes and Abbreviations" appearing at the beginning of each regular issue of the PCT Gazette.

DNA Isolation Method

The present invention relates to the isolation of DNA from cell samples, particularly mammalian blood, in a microfabricated apparatus, particularly in a CD device, prior to further analysis, for example DNA probing, amplification and sequencing.

There is a requirement to isolate DNA rapidly and conveniently from a variety of cellular sources, including blood. The availability of DNA has greatly facilitated the analysis and characterisation of the genome in many organisms through the application of sequencing and hybridisation techniques. Conventional approaches to DNA isolation and purification are based on multi-step procedures involving phenol/chloroform (see for example Sambrook, J. et al, *Molecular Cloning: A Laboratory Manual*, 2nd Edition, Cold Spring Harbor Laboratory Press, 1989). These processes are inherently laborious, may result in damaged DNA samples and are generally not amenable to automation. A number of non-toxic extraction procedures have been reported (*Nucleic Acids Research*, 15, 859, 1987; *Analytical Biochemistry*, 120, 282-288 1982), but these require either extensive dialysis or use of filters. Improved extraction methods include the use of chaotropic agents (*BioTechniques*, 22, 550-553, 1997). Others may be applicable to specific cell types and involve only lysis, dilution and addition to a PCR tube (*BioTechniques*, 11, 30-31, 1991).

US Patent No.5650506 (Becton Dickinson) relates to modified glass fiber membranes which exhibit sufficient hydrophilicity and electropositivity to bind DNA from a suspension containing DNA and permit elution of the DNA from the membrane. The modified glass fiber membranes are useful for purification of DNA from other cellular components. A product is also available based on isolation of DNA from blood on glass filters (GFX™ Genomic Blood DNA Purification Kit, Amersham Pharmacia Biotech).

US Patent Nos.5705628 and 5898071 disclose a method for separating polynucleotides, such as DNA, RNA and PNA, from a solution containing polynucleotides by reversibly and non-specifically binding the
5 polynucleotides to a solid surface, such as a magnetic microparticle. A similar approach has been used in a product, "Dynabeads DNA Direct" marketed by Dynal A/S, Norway.

US Patent No.5447864 discloses a method of separating cell nuclei
10 from cells by means of a pipette tip device, open at one end and having a membrane extending across its forward end. The method comprises treating a fluid containing whole cells so as to selectively lyse the cytoplasmic membrane, together with a small proportion of the nuclear membranes, but leaving a large proportion of the cell nuclei intact. The
15 treated fluid is applied to the membrane whereby a mesh of DNA from the lysed nuclei is formed on the surface and captures intact cell nuclei. The mesh comprising DNA on the surface is then washed to separate the captured cell nuclei from other components of the cells. A device for use in the method is also described, the device comprising a pipette tip having
20 a membrane that extends across its forward end.

Methods for the isolation of DNA in microstructured devices have demanded substantial simplification of conventional techniques that are
25 time-consuming and frequently require centrifugation, pipetting, vortexing or thermal incubation steps. One approach to the purification of DNA from whole blood is to isolate the white blood cells prior to direct PCR (Nucleic Acids Research, 24, 380-385, 1996), thus removing a primary inhibitor of PCR, namely haemoglobin. Another approach (Science, 282, 399-401, 1998) involves mixing blood with a salt solution that lyses the cells. The
30 lysate is then introduced into a chamber containing a glass wall on which DNA binds by charge interaction, while the rest of the sample is ejected.

The DNA is washed with ethanol/water mixes and then eluted to a neighbouring chamber.

WO 97/21090 relates to methods and apparatus for performing
5 micro-analytic and micro-synthetic procedures. The invention provides an apparatus comprising a rotatable disc which includes sample inlet port, fluid micro-channels, reaction chambers and outlet ports. Movement of fluids within the device, for example reagents, samples and other liquid components, is facilitated by rotation of the disc causing centripetal
10 acceleration of the fluids through the micro-channels embedded in the disc. Methods specific for the apparatus are provided for performing a variety of procedures, including DNA synthesis, micro-extraction and cell counting.

A method for the extraction and concentration of short (500bp) and
15 medium size (48000bp) DNA from test samples of bacteriophage lambda DNA utilising silicon fluidic microchips is disclosed in J.Biomechanical Engineering, 121, 23-27 (1999). PCR and gel electrophoresis were used to analyse the nucleic acid obtained by this process.

20 The serial nature of the procedures for DNA isolation described above limits throughput. Moreover, such procedures are not readily amenable to automation. Sample preparation has consistently been demonstrated as the rate-limiting step in procedures which require the input of genomic DNA. The present invention relates to the isolation of
25 DNA in a format which permits multiple cell samples to be processed in parallel. The complex sequential extraction processes of conventional methods of DNA isolation are performed seamlessly in parallel using microfluidics, in contrast with multi-channel and microwell pipetting procedures where each well must be accessed individually to add or
30 remove reagents.

Accordingly, the present invention provides a method of isolating DNA and/or cell nuclei in a microfabricated apparatus that contains a plurality of micro-channels the method comprising forming a mesh in one or more of the micro-channels that acts as a barrier to DNA and/or cell
5 nuclei.

Preferably the mesh formed in the said one or more micro-channels of the microfabricated apparatus comprises a mesh of nucleic acid.

10 In one aspect of the invention, there is provided a method of isolating DNA or cell nuclei or a mixture thereof from cells, which method comprises:

- a) treating a suspension of whole cells with a lysis reagent so as to
15 lyse the cytoplasmic membranes and at least some of the nuclear membranes;
- b) introducing the lysate from step a) into micro-channels of a microfabricated apparatus wherein each of said micro-channels
20 incorporates means to impede the passage or flow of DNA and cell nuclei while allowing the passage of liquid through the micro-channel whereby a mesh comprising DNA is formed in the channel; and,
- c) washing the mesh comprising DNA.

25

Where it is desired to isolate cell nuclei, suitably step a) should be performed wherein a proportion of the nuclear membranes is left intact.

In another aspect of the present invention there is provided
30 microfabricated apparatus for isolating DNA or cell nuclei or a mixture thereof from cells, which apparatus comprises a rotatable disc, the disc

comprising a sample introduction port located towards the centre of the disc in contact with an annular sample reservoir which in turn is connected to a plurality of radially dispersed micro-channels, each micro-channel comprising an inlet channel and an outlet channel disposed towards the circumferential edge of the disc and means incorporated in each of the micro-channels to impede the passage or flow of DNA and cell nuclei, while allowing the passage of liquid therethrough.

Suitably, the means incorporated in each of the micro-channels to impede the passage or flow of DNA and cell nuclei comprises a barrier.

In one preferred embodiment of the present invention, the barrier comprises beads that impede the flow or passage of DNA and cell nuclei in the micro-channel, while allowing the passage of liquid. In a second preferred embodiment of the present invention, the barrier comprises raised structures disposed in the micro-channel. Preferably, the raised structures are moulded, for example to form pillars. In a particularly preferred embodiment of the invention, the raised structures are disposed on the base portion of the micro-channel and are moulded to form pillars such that they impede the flow or passage of DNA and cell nuclei in the micro-channel, while allowing the passage of liquid.

The method of the present invention may be used for the isolation of DNA or cell nuclei from any suitable nucleated cell source, for example from plant cells and animal cells. The invention is particularly suitable for the isolation of mammalian cell DNA, more particularly DNA from whole blood. Suitably, step a) of the method may be performed in a separate vessel prior to introduction of the cell lysate into the micro-channels of the microfabricated apparatus. Alternatively, step a) may be performed within the microfabricated apparatus, for example by treating the suspension of whole cells contained within the annular sample reservoir with the lysis

reagent, prior to introduction of the lysate into the micro-channels of the apparatus.

Beads employed in the method of the invention may be of any
5 suitable composition, for example plastics materials. Suitable plastics may
be porous or non-porous, depending upon the degree of cross-linking in the
polymer and they include polystyrene, styrene acrylate co-polymer,
polystyrene cross-linked with divinylbenzene, polyvinyltoluene,
polymethacrylate and polycarbonate. Alternative materials include
10 polysaccharides (such as dextran), metal oxides (such as aluminium oxide),
glass and carbon. Optionally, the surface of the beads may be treated or
activated by chemical or by physical means, for example by derivatisation
with positively charged species, so as to render the surface more
susceptible to binding by DNA.

15

Preferably at least some of the micro-channels of the microfabricated
apparatus each further comprise a reaction chamber for performing assays
or processing DNA and being connected in-line downstream of the barrier.

20

In order that the invention may be better understood, the
embodiments will now be described by way of example only and with
reference to the accompanying drawings in which:

Figure 1 is a plan view of a microfabricated disc for performing DNA
25 isolation;

Figure 2a is a diagrammatic representation in plan of an individual micro-
channel element of a microfabricated apparatus containing microbeads for
DNA isolation;

30

Figure 2b is a diagrammatic representation in plan of an individual micro-channel of a microfabricated apparatus in which the micro-channel is provided with raised structures disposed on the base portion of the micro-channel to form pillars;

5

Figure 2c is a diagrammatic representation in plan of an individual micro-channel of a microfabricated apparatus in which micro-beads are contained within a chamber formed in the micro-channel;

10 Figure 2d is a diagrammatic representation in plan of an individual micro-channel of a microfabricated apparatus in which raised structures are disposed within a chamber formed in the micro-channel;

Figure 3 is an image showing DNA from whole human blood with EDTA as
15 anticoagulant captured with beads according to the method of the invention and visualised with PicoGreen stain using an epifluorescence microscope; and,

Figure 4 is an image from a control sample in which PBS buffer was passed
20 through the micro-channel according to the method.

The present invention provides a method for isolating DNA from cells using a microfabricated apparatus (shown in Figure 1) comprising a rotatable disc (1) microfabricated to provide a sample introduction port (not
25 shown) located towards the centre of the disc and connected to an annular sample reservoir (2) which in turn is connected to a plurality of radially dispersed micro-channels (3). Each of the micro-channels (3) comprises a sample inlet channel (4) and an outlet channel (5) disposed towards the circumferential edge of the disc for removal of liquid and or samples
30 therefrom. A cover plate (not shown) is positioned onto the disc so as to define closed chambers and connecting channels. Each micro-channel is

connected at one end to the annular sample reservoir (2) and at the opposite end to a common waste channel (6).

- Suitably the disc (1) is of a one- or two-piece moulded construction and is formed of an optionally transparent plastic or polymeric material by means of separate mouldings which are assembled together to provide a closed structure with openings at defined positions to allow loading of the device with liquids and removal of liquid samples. Suitable plastic or polymeric materials may be selected to have hydrophobic properties.
- 5 Preferred plastics or polymeric materials are selected from polystyrene and polycarbonate. In the alternative, the surface of the micro-channels may be additionally selectively modified by chemical or physical means to alter the surface properties so as to produce localised regions of hydrophobicity or hydrophilicity within the micro-channels to confer a desired property.
- 10 Preferred plastics are selected from polymers with a charged surface, suitably chemically or ion-plasma treated polystyrene, polycarbonate or other rigid transparent polymers.
- 15

In its simplest form, the device is produced as two complementary parts, one or each carrying moulded structures which, when affixed together, form a plurality of micro-channels within the body of a solid disc and being radially disposed about the centre. Alternatively the micro-channels may be formed by micro-machining methods in which the micro-channels are micro-machined into the surface of a disc, and a cover plate, for example a plastic film, is adhered to the surface so as to enclose the channels.

20

25

The individual micro-channels (3) of the microfabricated apparatus are shown in Figures 2a-2d. In one preferred aspect (shown in Figure 2a), each of the micro-channels (10) comprises a sample inlet channel (11) connected at its left hand end to the reservoir (2), leading through channel

30

(12) to a reaction chamber (15) and an outlet channel (13) connected at its right-hand end to the waste channel (6). Each micro-channel contains a layer or "plug" of micro-beads (14) upstream of the reaction chamber (15) and held in place by means of a stepped wall or interface of the micro-channel (16). The "plug" of beads acts to capture DNA and cell nuclei passing through the micro-channel, while allowing the passage of liquid. Advantageously, channel (11) upstream of the interface (16) is characterised by having a larger cross-sectional area than channel (12) downstream of the interface (16). Suitably the cross-sectional area of the channel (12) downstream of the interface (16) is between 0.99 and 0.01 times that of the channel upstream of the interface and is suitably of dimensions which do not allow the passage of the microbeads, which will form a "plug" at the interface between the upstream and downstream channels.

15

In a second preferred aspect of the present invention (shown in Figure 2b), each of the micro-channels (20) comprises a sample inlet channel (21) connected at its left hand end to the reservoir (2), leading through channel (12) connected to a reaction chamber (23) and an outlet channel (22) connected at its right-hand end to the waste channel (6). The channel (21) upstream of the reaction chamber (23) is provided with raised structures disposed on the base portion of the micro-channel. The raised structures are moulded to form pillars (24), such that they form a barrier to the flow or passage of DNA and cell nuclei arriving thereto, while allowing the passage of liquid.

25

In another preferred aspect of the invention (shown in Figure 2c), each of the micro-channels (30) comprises an inlet channel (31) connected at its left hand end to the reservoir (2), a chamber (34) containing a plurality of micro-beads (35) for use in performing the method of the invention, and connected through a channel (32) to reaction chamber (36)

30

and an outlet channel (33), leading to the common waste channel (6). Advantageously, the channel (32) which connects chamber (34) with the reaction chamber (36) is characterised by having a cross-sectional area between 0.99 and 0.01 times that of the channel (31) upstream of the chamber (34) and is of dimensions which do not allow the passage of the microbeads, thereby causing the "plug" of beads to be concentrated in the chamber.

In a further preferred aspect of the present invention (shown in Figure 2d), each of the micro-channels (40) comprises an inlet channel (41) connected at its left hand end to the reservoir (2), a chamber (44) connected through a channel (42) to reaction chamber (46) and an outlet channel (43), leading to the common waste channel (6). The chamber (44) may be provided with raised structures disposed on the base portion of the chamber. The raised structures are moulded to form pillars (45), such that they form a barrier to the flow or passage of cells arriving thereto, while allowing the passage of liquid.

Suitably, chambers (34, 44) are sized to give a floor area between $100\mu\text{m}^2$ and $4,000,000\mu\text{m}^2$, preferably between $1000\mu\text{m}^2$ and $1,000,000\mu\text{m}^2$ and most preferably between $10,000\mu\text{m}^2$ and $1,000,000\mu\text{m}^2$.

The micro-channels are suitably of dimensions compatible with movement of cell nuclei. Suitably, the micro-channels may be of any cross-sectional shape, such as square, rectangular, circular, trapezoid and triangular and will typically have dimensions of the order $20\text{-}30\mu\text{m}$ or greater. Suitably micro-channels of width $250\mu\text{m}$ may be used.

Preferably as shown in Figures 2a-2d, each of the micro-channels is provided with a reaction chamber (15, 23, 36, 46) for manipulation of the

DNA or for performing assays using DNA isolated by the method of the invention, and being connected in-line downstream of the barrier. The reaction chamber is suitably between twice and one tenth of the volume of chambers (34, 44). Typically, a suitable volume of reactants for
5 performing an assay or manipulating DNA prepared by the method of the invention is between 10nl and 1 μ l. Suitably, the outlet channels (13, 22, 33, 43) are characterised by having a cross-sectional area between 0.99 and 0.01 times that of the channels (12, 20, 32, 42) upstream of the reaction chambers (15, 23, 36, 46).

10

The raised structures (pillars) formed in the micro-channels (24) or chambers (45) are of dimensions chosen to provide gaps between the structures that are too narrow to allow passage of cell nuclei carried as a liquid suspension in the device, while allowing the passage of liquid.
15 Suitable dimensions for the gaps between the raised pillars formed in the micro-channels (24) or in the chambers (45) of the apparatus are between 5 μ m and 50 μ m, depending upon the cell nuclei type and size selected for capture.

20 Beads employed in the method of the invention may be of any suitable composition, for example plastics materials. Suitable plastics may be porous or non-porous depending upon the degree of cross-linking in the polymer and include polystyrene, styrene acrylate co-polymer, polystyrene cross-linked with divinylbenzene, polyvinyltoluene, polymethacrylate and
25 polycarbonate. Alternative materials include polysaccharides (such as dextran), metal oxides (such as aluminium oxide), glass and carbon. Preferably the surface of the beads is of a material which is capable of binding DNA, for example by hydrophobic bonding, charge interaction, or physical adsorption. A charged surface on the beads may favour
30 electrostatic interaction, while an uncharged polymer surface may promote hydrophobic bonding. The surface of the beads may therefore be treated

or activated by chemical or physical means to improve the binding capability of DNA. For example, the surface of the beads may be derivatised or modified with positively charged chemical groups as would be known to the skilled person in order to render the surface more susceptible to binding by DNA. Binding may be further improved by application of additional coating to the surface of the beads , eg. polylysine. Bead size suitable for DNA capture is suitably between 5µm and 100µm, preferably between 15µm and 50µm.

10 The nature and source of the cells is not critical to the invention. That is, nucleated cells from any source may be used, including plant cells and animal cells. The invention is particularly useful for the isolation of cell nuclei and DNA from mammalian cells, including whole blood. The first stage of the method for isolating cell nuclei from cells is the selective lysis of the cell membrane of whole cells together with a small proportion of the nuclear membranes. This stage of the method may be performed in a suitable vessel and the cell lysate transferred to the annular sample reservoir of the microfabricated apparatus. Alternatively, a cell suspension may be introduced into the sample reservoir and the lysis buffer then added so as to lyse the cytoplasmic membranes and some of the nuclear membranes according to the method. Protocols for the lysis of cells according to the method of the invention are disclosed in US Patent No.5447864. For example, a lysis buffer containing 10mM Tris pH 8.0, 320mM sucrose and 1% Triton X-100 may be used to lyse red cells and white cell membranes and some nuclear membranes, by incubating the cells at room temperature for 5 minutes. Alternative lysis buffers which are suitable in the method of the invention are anionic detergents such as SDS (sodium dodecyl sulphate).

30 The cell lysate mixture obtained as described above is introduced into the inlet channel of each of the micro-channels of the microfabricated

apparatus (1) and the disc is rotated by suitable means and at a speed sufficient to cause movement of the cell lysate outward towards the periphery of the disc by centripetal force and along each of the inlet channels (4) towards the barrier of beads or pillars formed in the micro-channels of the disc. In this way, rotation of the disc causes the cell lysate to flow towards the barrier disposed in the micro-channel and to form a mesh comprising DNA for capture of further DNA, or cell nuclei. Alternatively, the cell lysate mixture may be applied as discrete droplets onto the hydrophobic surface of the stationary disc, rotation of the disc being used to move the mixture into the appropriate micro-channel for capture of DNA and cell nuclei at the barrier. The captured DNA mesh is then washed by passing a washing solution through the mesh formed in the micro-channel. The wash solution is introduced into the microfabricated apparatus via the inlet channel of each micro-channel and the disc is rotated so as to cause movement of the wash solution along the micro-channels and through the DNA mesh captured therein.

Following the wash step to remove contaminants present in the captured DNA and cell nuclei, the cell nuclei captured by the mesh are further treated to release DNA by passing a solution containing a lysis reagent through each micro-channel. The lysis reagent is one which is capable of disrupting the nuclear envelope. For example, a reagent containing 0.5% (w/v) sodium dodecyl sulphate and proteinase K (250µg/ml) in a phosphate buffered saline solution may be used. Alternatively, the nuclear membranes of the cell nuclei captured in the DNA mesh may be disrupted by heating the disc at a temperature between 80°C and 95°C for 1 - 30 minutes.

Following release, the nuclear DNA may be removed from the barrier by washing. Processing of the DNA obtained by the method of the invention may be carried out either on the mesh, or the DNA may be

5 moved by centripetal force towards the periphery of the microfabricated apparatus for subsequent processing. In this case, the individual micro-channels of the microfabricated apparatus may be provided with a reaction chamber disposed closer to the periphery of the disc and connected in-line in the micro-channel between the barrier means and the outlet channel. The reaction chamber is connected to the common waste channel by a narrow channel having a smaller diameter than that upstream of the reaction chamber. The difference in diameters of the channels allows, under controlled conditions of rotation and centripetal force as discussed above, samples of DNA isolated by the method of the invention to be moved from the locus of the barrier to the reaction chamber and allowing subsequent additions of reagents for processing or manipulating the DNA.

15 The DNA isolated by the method of the invention is suitable for PCR or other processes. If restriction of the DNA is required, then restriction digests may be carried out *in-situ* on the mesh. The restriction digested DNA may likewise be moved to the reaction chamber for subsequent processing, by rotating the disc at a suitable speed.

20 The invention is further illustrated by reference to the following examples.

Example 1

25 In a specific experiment the following steps were taken in which liquids were introduced into the micro-channel by suction :

30 A micro-channel of the following dimensions (4000 μ m long x 120 μ m wide with a depth of 60 μ m for half the length and 10 μ m for the rest of the channel) was loaded with a small volume of rigid monodisperse spherical plastic beads (polystyrene cross-linked with underivatised divinylbenzene,

SOURCE™ particles, Amersham Pharmacia Biotech) with a diameter of 15µm. These formed a thin layer of beads at the interface between the deep and shallow regions of the micro-channel (see Figure 2a).

5 5µl of whole EDTA blood were mixed with an equal volume of Lysis Buffer containing 10mM Tris pH 8.0, 320mM sucrose, 5mM MgCl₂ and 1% (v/v) Triton X-100, and incubated at room temperature for 5 minutes. The lysate was diluted ten-fold with a 1:1 mixture of Lysis Buffer and Phosphate Buffered Saline (PBS, Sigma). A volume of 0.4µl of the diluted
10 lysate was drawn through the micro-channel containing the beads. The beads were washed with 1µl of PBS followed by 1µl of a 1:200 dilution of PicoGreen (a specific fluorescent stain for double-stranded DNA; Molecular Probes Inc., USA) in TE (10mM Tris/HCl, 1mM EDTA, pH 7.5), followed by 1µl of TE only.

15

The beads were examined using an epifluorescence microscope with an activation wavelength of approximately 480nm and emission wavelength of approximately 520nm to visualise the PicoGreen stain bound to the DNA on the beads (shown in Figure 3). Controls, in which PBS
20 substituted the blood, were run through the same process giving only background fluorescence of the beads packed at the interface between deep and shallow sections of the micro-channel (shown in Figure 4).

Example 2

25

DNA was isolated from frozen citrate blood on a shallow bead bed as in described in Example 1 except that it was not visualised with PicoGreen. In this case a somewhat larger channel was used (4000µm long x 500µm wide with a depth of 55µm for half the length and 10µm for
30 the rest of the channel).

A solution containing the following reagents was introduced into the chamber to lyse the nuclei and release the DNA: 10mM Tris/HCl, pH 8; 0.5% SDS; 1mg/ml Proteinase K. The reaction mixture was incubated at 55°C for 5 minutes. The contents of the chamber were washed out with 5 1µl of a solution containing the following components: 1 x PCR Buffer II (Perkin Elmer ABI); 6% (w/v) α-cyclodextrin (Aldrich). The resulting liquid was collected and diluted to 10µl with water.

PCR was run on the extracted DNA as follows:

10

Five microlitres of diluted DNA were added to a PCR mixture (final volume 25µl) containing the following components: 1 x PCR buffer II (Perkin Elmer ABI); 1.5mM MgCl₂; 200 µM deoxynucleotides; 1 U AmpliTaq Gold (Perkin Elmer ABI); 15pmol of each primer specific for a 1035 bp region of the 15 CYP2D6 gene covering exon 2 and part of the flanking introns. The reaction mixture was cycled using the following protocol: 95°C x 9 min; (95°C x 15s, 60°C x 30s, 72°C x 45s) x 35; 72°C x 5 min.

Products were analysed by agarose gel electrophoresis and staining 20 with ethidium bromide followed by visualisation under UV light. Clearly visible PCR products were obtained from the test DNA. Product was absent in negative controls and present in positive controls containing pure DNA isolated by another method.

25

The PCR products were diluted 1:1000 and 2.5µl of this diluted template were added to a second PCR mixture (final volume 25µl) containing the same components as the first excepting the primers which covered a 262bp region including exon 2 of CYP2D6, and AmpliTaq was used. The cycle program was the same with the omission of the initial 30 incubation at 95°C required only when using AmpliTaq Gold. Similar

reactions were done using 1 μ l of the original diluted DNA isolate (i.e. non-nested amplification of the original DNA was attempted).

Agarose electrophoresis again indicated the presence of PCR
5 products generated from the isolated DNA. In this case, the nested PCR
gave very strong amplification. Weak but clearly visible products were
also obtained when using the original DNA directly in the PCR. Negative
and positive controls gave expected results.

10

15

20

25

30

Claims

1. A method of isolating DNA and/or cell nuclei in a microfabricated apparatus that contains a plurality of micro-channels the method
5 comprising forming a mesh in one or more of the micro-channels that acts as a barrier to DNA and/or cell nuclei.
2. The method according to claim 1 wherein the mesh formed in the said one or more micro-channels of the microfabricated apparatus
10 comprises a mesh of nucleic acid.
3. A method of isolating DNA or cell nuclei or a mixture thereof from cells, which method comprises:
 - 15 a) treating a suspension of whole cells with a lysis reagent so as to lyse the cytoplasmic membranes and at least some of the nuclear membranes;
 - b) introducing the lysate from step a) into micro-channels of a
20 microfabricated apparatus wherein each of said micro-channels incorporates means to impede the passage or flow of DNA and cell nuclei while allowing the passage of liquid through the micro-channel whereby a mesh comprising DNA is formed in the channel; and,
 - 25 c) washing the mesh comprising DNA.
4. The method according to claim 3 wherein in step a) a proportion of the nuclear membranes is left intact
- 30 5. The method according to claims 3 or 4 wherein the microfabricated apparatus comprises a rotatable disc, the disc comprising a sample

introduction port located towards the centre of the disc in contact with an annular sample reservoir which in turn is connected to a plurality of radially dispersed micro-channels, each micro-channel comprising an inlet channel and an outlet channel disposed towards the circumferential edge of the disc and means incorporated in each of the micro-channels to impede the passage or flow of DNA and cell nuclei, while allowing the passage of liquid therethrough.

6. The method according to claims 3 to 5 wherein said means incorporated in each of the micro-channels to impede the passage or flow of DNA and cell nuclei comprises a barrier.

7. The method according to claim 6 wherein said barrier comprises beads that impede the flow or passage of DNA and cell nuclei in the micro-channel while allowing the passage of liquid.

8. The method according to claim 7 wherein said beads are selected from polystyrene, styrene acrylate co-polymer, polystyrene cross-linked with divinylbenzene, polyvinyltoluene, polymethacrylate, polycarbonate, polysaccharides, metal oxides, glass and carbon.

9. The method according to claim 6 wherein said barrier comprises raised structures disposed in the micro-channel.

10. The method according to claim 9 wherein said raised structures are disposed on the base portion of the micro-channel and are moulded to form pillars such that they impede the flow or passage of DNA and cell nuclei in the micro-channel while allowing the passage of liquid.

11. The method according to any of claims 3 to 10 wherein at least some of the micro-channels of the microfabricated apparatus each further comprise a reaction chamber for performing assays or processing DNA.
- 5 12. The method according to claims 3 to 11 wherein the whole cells of step a) are selected from plant cells and animal cells.
13. The method according to claims 3 to 12 wherein step c) is performed by passing a washing solution through the mesh formed in the
10 micro-channel.
14. The method according to claims 3 to 13 wherein cell nuclei captured by the mesh are further treated to release DNA.
- 15 15. Microfabricated apparatus for isolating DNA or cell nuclei or a mixture thereof from cells, which apparatus comprises a rotatable disc, the disc comprising a sample introduction port located towards the centre of the disc in contact with an annular sample reservoir which in turn is connected to a plurality of radially dispersed micro-channels, each micro-
20 channel comprising an inlet channel and an outlet channel disposed towards the circumferential edge of the disc and means incorporated in each of the micro-channels to impede the passage or flow of DNA and cell nuclei, while allowing the passage of liquid therethrough.
- 25 16. The apparatus according to claim 15 wherein said means incorporated in each of the micro-channels to impede the passage or flow of DNA and cell nuclei comprises a barrier.
17. The apparatus according to claim 16 wherein said barrier comprises
30 beads that impede the flow or passage of DNA and cell nuclei in the micro-channel, while allowing the passage of liquid.

18. The apparatus according to claim 17 wherein said beads are selected from polystyrene, styrene acrylate co-polymer, polystyrene cross-linked with divinylbenzene, polyvinyltoluene, polymethacrylate, polycarbonate,
5 polysaccharides, metal oxides, glass and carbon.

19. The apparatus according to claim 16 wherein said barrier comprises raised structures disposed in the micro-channel.

10 20. The apparatus according to claim 19 wherein said raised structures are disposed on the base portion of the micro-channel and are moulded to form pillars.

21. The apparatus according to any of claims 15 to 20 wherein at least
15 some of the micro-channels of the microfabricated apparatus each further comprise a reaction chamber for performing assays or processing DNA.

22. DNA isolated by the method according to any one of claims 1 to 14.

20

25

30

Figure 1/4

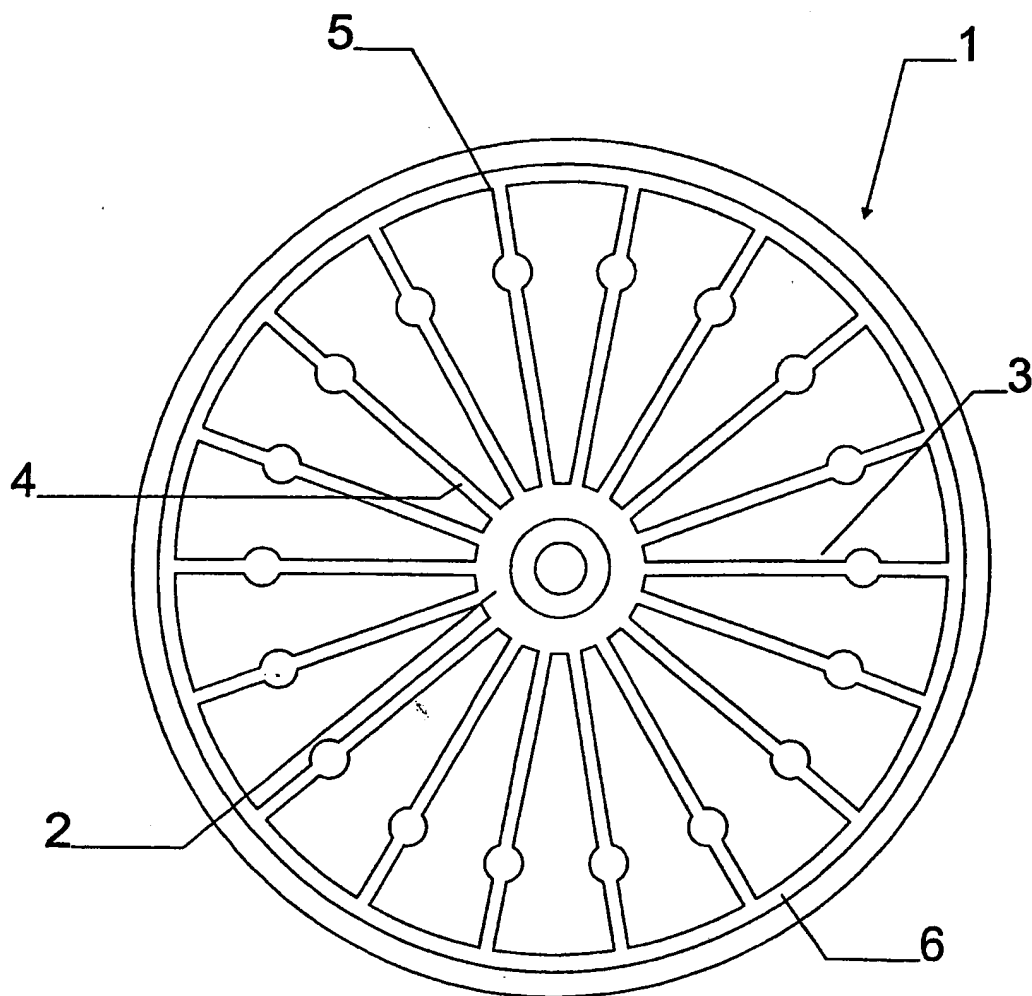

Figure 2/4

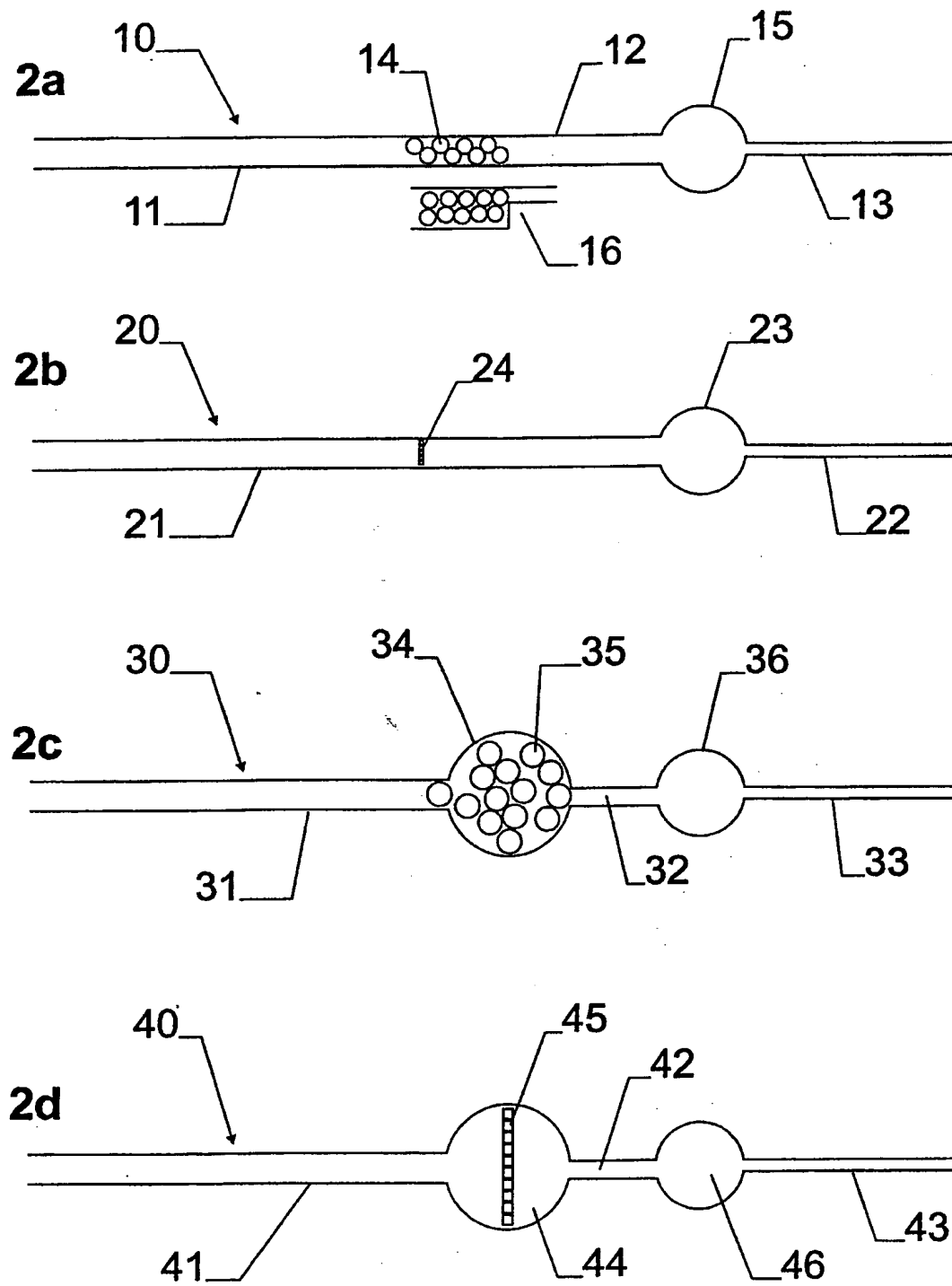
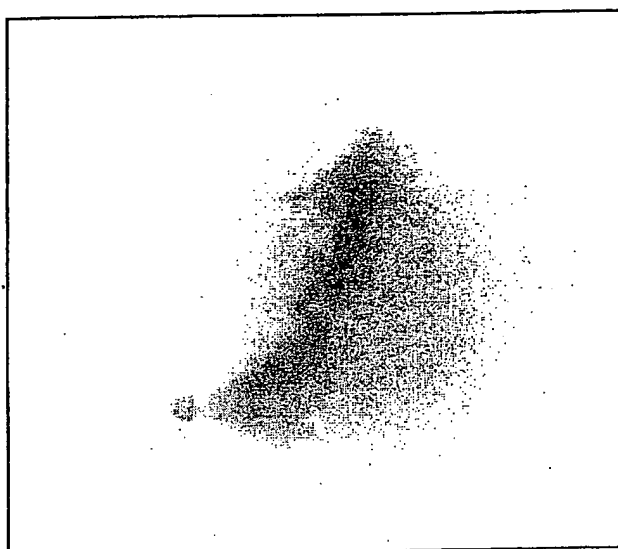

Figure 3/4



Figure 4/4



INTERNATIONAL SEARCH REPORT

International Application No
PCT/GB 00/04047

A. CLASSIFICATION OF SUBJECT MATTER IPC 7 C12N15/10 C12M3/04 B01L3/00		
According to International Patent Classification (IPC) or to both national classification and IPC		
B. FIELDS SEARCHED Minimum documentation searched (classification system followed by classification symbols) IPC 7 C12N C12M B01L		
Documentation searched other than minimum documentation to the extent that such documents are included in the fields searched		
Electronic data base consulted during the international search (name of data base and, where practical, search terms used) WPI Data, PAJ, CAB Data, STRAND, BIOSIS, EPO-Internal		
C. DOCUMENTS CONSIDERED TO BE RELEVANT		
Category *	Citation of document, with indication, where appropriate, of the relevant passages	Relevant to claim No.
X	WO 97 21090 A (GAMERA BIOSCIENCE) 12 June 1997 (1997-06-12) cited in the application claims 1-84; figures 1,17,18; examples 3-7	15,29
X	EP 0 693 560 A (BECTON DICKINSON CO) 24 January 1996 (1996-01-24) the whole document	1,15,29
X	US 5 593 838 A (ZANZUCCHI PETER J ET AL) 14 January 1997 (1997-01-14) the whole document	29
X	US 5 637 469 A (WILDING PETER ET AL) 10 June 1997 (1997-06-10) the whole document	29

-/-		
<input checked="" type="checkbox"/> Further documents are listed in the continuation of box C.		
<input checked="" type="checkbox"/> Patent family members are listed in annex.		
* Special categories of cited documents :		
A document defining the general state of the art which is not considered to be of particular relevance *E* earlier document but published on or after the international filing date *L* document which may throw doubts on priority claim(s) or which is cited to establish the publication date of another citation or other special reason (as specified) *O* document referring to an oral disclosure, use, exhibition or other means *P* document published prior to the international filing date but later than the priority date claimed	*T* later document published after the international filing date or priority date and not in conflict with the application but cited to understand the principle or theory underlying the invention *X* document of particular relevance: the claimed invention cannot be considered novel or cannot be considered to involve an inventive step when the document is taken alone *Y* document of particular relevance: the claimed invention cannot be considered to involve an inventive step when the document is combined with one or more other such documents, such combination being obvious to a person skilled in the art. *&* document member of the same patent family	
Date of the actual completion of the international search	Date of mailing of the international search report	
28 February 2001	07/03/2001	
Name and mailing address of the ISA	Authorized officer	
European Patent Office, P.B. 5818 Patentlaan 2 NL - 2280 HV Rijswijk Tel. (+31-70) 340-2040, Tx. 31 651 epo nl, Fax (+31-70) 340-3016	Hornig, H	

INTERNATIONAL SEARCH REPORT

International Application No
PCT/GB 00/04047

C.(Continuation) DOCUMENTS CONSIDERED TO BE RELEVANT		
Category *	Citation of document, with indication, where appropriate, of the relevant passages	Relevant to claim No.
X	WO 99 09042 A (CEPHEID) 25 February 1999 (1999-02-25) page 19, line 27 -page 20, line 6; claims 1-42; figures 1-15 page 25, line 15 -page 26, line 9 -----	29
P,X	WO 99 55827 A (AMERSHAM PHARM BIOTECH UK LTD ;THOMAS NICHOLAS (GB)) 4 November 1999 (1999-11-04) the whole document -----	15-21
E	WO 00 78455 A (KELLOGG GREGORY J ;KIEFFER HIGGINS STEPHEN (US); SHEPPARD NORMAN F) 28 December 2000 (2000-12-28) claims 1-45; figures 1-27; examples 1-4 -----	29

INTERNATIONAL SEARCH REPORT

Information on patent family members

International Application No

PCT/GB 00/04047

Patent document cited in search report	Publication date	Patent family member(s)	Publication date
WO 9721090 A	12-06-1997	AU 702403 B	18-02-1999
		AU 1283397 A	27-06-1997
		CA 2239613 A	12-06-1997
		CN 1208464 A	17-02-1999
		EP 0865606 A	23-09-1998
		NO 982563 A	05-08-1998
		AU 4144897 A	06-03-1998
		EP 0917648 A	26-05-1999
		WO 9807019 A	19-02-1998
		US 6143248 A	07-11-2000
EP 0693560 A	24-01-1996	US 5639428 A	17-06-1997
		AU 2331095 A	01-02-1996
		BR 9503364 A	27-02-1996
		CA 2152307 A	20-01-1996
		JP 8062225 A	08-03-1996
		SG 32408 A	13-08-1996
US 5593838 A	14-01-1997	US 5585069 A	17-12-1996
		AU 705351 B	20-05-1999
		AU 4152396 A	06-06-1996
		AU 705659 B	27-05-1999
		AU 4233796 A	06-06-1996
		CA 2204912 A	23-05-1996
		CA 2205066 A	23-05-1996
		EP 0791238 A	27-08-1997
		EP 0808456 A	26-11-1997
		JP 11500602 T	19-01-1999
		WO 9615450 A	23-05-1996
		WO 9615576 A	23-05-1996
		US 5681484 A	28-10-1997
		US 5643738 A	01-07-1997
		US 5846396 A	08-12-1998
		US 5985119 A	16-11-1999
		US 5755942 A	26-05-1998
		US 5863708 A	26-01-1999
US 5858804 A	12-01-1999		
US 5637469 A	10-06-1997	US 5866345 A	02-02-1999
		AT 155711 T	15-08-1997
		AT 167816 T	15-07-1998
		AT 140025 T	15-07-1996
		AT 140880 T	15-08-1996
		AT 174813 T	15-01-1999
		AU 677780 B	08-05-1997
		AU 4222393 A	29-11-1993
		AU 680195 B	24-07-1997
		AU 4222593 A	29-11-1993
		AU 677781 B	08-05-1997
		AU 4222693 A	29-11-1993
		AU 4222793 A	29-11-1993
		AU 677197 B	17-04-1997
		AU 4223593 A	29-11-1993
		CA 2134474 A	11-11-1993
		CA 2134475 A	11-11-1993
		CA 2134476 A	11-11-1993
		CA 2134477 A	11-11-1993
		CA 2134478 A	11-11-1993

INTERNATIONAL SEARCH REPORT

Information on patent family members

International Application No

PCT/GB 00/04047

Patent document cited in search report	Publication date	Patent family member(s)	Publication date	
US 5637469 A		DE 69303483 D	08-08-1996	
		DE 69303483 T	06-02-1997	
		DE 69303898 D	05-09-1996	
		DE 69303898 T	20-02-1997	
		DE 69312483 D	04-09-1997	
		DE 69312483 T	12-02-1998	
		DE 69319427 D	06-08-1998	
		DE 69319427 T	10-12-1998	
		DE 69322774 D	04-02-1999	
		DE 69322774 T	17-06-1999	
		EP 0637996 A	15-02-1995	
		EP 0637997 A	15-02-1995	
		EP 0639223 A	22-02-1995	
		EP 0637998 A	15-02-1995	
		EP 0637999 A	15-02-1995	
		ES 2106341 T	01-11-1997	
		ES 2127276 T	16-04-1999	
		GR 3025037 T	30-01-1998	
		GR 3029509 T	28-05-1999	
		HK 16897 A	13-02-1997	
		JP 7506430 T	13-07-1995	
		JP 7506431 T	13-07-1995	
		JP 7506256 T	13-07-1995	
		JP 7506257 T	13-07-1995	
		JP 7506258 T	13-07-1995	
		WO 9322053 A	11-11-1993	
		WO 9322054 A	11-11-1993	
		WO 9322421 A	11-11-1993	
		WO 9322055 A	11-11-1993	
	WO 9909042 A	25-02-1999	AU 8906698 A	08-03-1999
			EP 1003759 A	31-05-2000
AU 1947299 A			19-07-1999	
EP 1042061 A			11-10-2000	
WO 9933559 A			08-07-1999	
WO 9955827 A	04-11-1999	EP 1073709 A	07-02-2001	
WO 0078455 A	28-12-2000	NONE		